

EST. 1889

# ANTON'S LANDING

*Labor omnia vincit*

**To: Anton's Landing Visitor**  
**From: Lawson Crout, Developer**  
**RE: Anton's Landing**

**Thank you for your interest in the unique new Anton's Landing community in Oklahoma City. Join us as we transform the historic Swatek homestead and farm into a community of authentic urban farm homes. We have used Open Space design principles to create a safe, park like atmosphere for our residents. Efforts are being made to preserve the undisturbed landscape enjoyed by early Oklahomans.**

**This 102 acre gated community includes only 108 urban home sites served by full city utilities. Lot sizes range from 1/3 to over 1 acre each, and minimum home sizes range from 2200 to 4000 square feet depending on location in the community.**

**Enclosed please find a plat showing lot availability, a price sheet, a list of our Exclusive Builders with their contact information and a synopsis of the Covenants & Restrictions. The Covenants & Restrictions in their entirety can be found on our website.**

**Our builders are ready to prepare your perfect urban farm home in Anton's Landing. If you have any questions, or to reserve your lot, please call or email soon.**

[www.croutcompanies.com](http://www.croutcompanies.com)

P.O. Box 250 ~ 1452 N. Mustang Rd., Suite 108~ Mustang, OK 73064

For information call 405-376-3704 or email: [lindsay.croutcompanies@yahoo.com](mailto:lindsay.croutcompanies@yahoo.com)

*Doing Right By The Land In Mustang Since 1977*

# Anton's Landing

## Lot Inventory - Phase I

<u>Lot</u>	<u>Block</u>	<u>Status</u>	<u>Min. Sq. Ft.</u>	<u>Notes</u>	<u>Acre</u>	<u>Pricing</u>
1	1	Available	2200		0.37	\$ 88,900
2	1	Available	2200		0.37	\$ 88,900
3	1	Available	2200		0.35	\$ 88,900
4	1	Contract	2200		0.40	\$ 88,900
5	1	Available	2200		0.44	\$ 89,900
6	1	Sold	2200		0.50	\$ 89,900
7	1	Available	2200		0.34	\$ 88,900
8	1	Available	2200		0.35	\$ 88,900
9	1	Available	2200		0.37	\$ 88,900
10	1	Available	2200		0.38	\$ 88,900
11	1	Available	2200		0.37	\$ 88,900
12	1	Available	2200		0.38	\$ 88,900
13	1	Available	2200		0.43	\$ 89,900
1	2	Sold	2200		0.53	Sold
2	2	Available	2200		0.45	\$ 88,900
3	2	Sold	2200		0.51	Sold
4	2	Sold	2200		0.54	Sold
5	2	Available	2200		0.48	\$ 89,900
6	2	Available	2200		0.43	\$ 88,900
7	2	Tagged	2200		0.43	\$ 88,900
8	2	Tagged	2200		0.47	\$ 88,900
9	2	Sold	2200		0.60	Sold
10	2	Sold	2200		0.45	Sold
11	2	Sold	2200		0.56	Sold
12	2	Available	2200		0.46	\$ 88,900
13	2	Available	2200		0.45	\$ 88,900
14	2	Sold	2200		0.48	Sold
15	2	Sold	2200		0.49	Sold
16	2	Sold	2200		0.59	Sold

EST. 1889

# ANTON'S LANDING

*Laborem omnia vincit*

## PHASE 1 DECEMBER 2023

SWATEK FAMILY LP  
QUIT CLAIM DEED  
BOOK 10647 PAGE 580

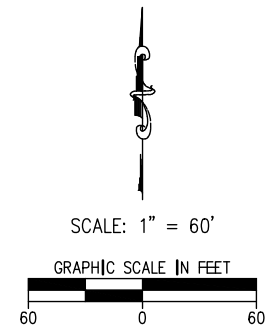

# **Anton's Landing** **Builders List**

## **J. Hill Homes**

Jeremy Hill (405)408-9602

[jhillhomes@gmail.com](mailto:jhillhomes@gmail.com)

[www.jhillhomes.com](http://www.jhillhomes.com)

## **Platinum Homes, LLC**

Josh Julian (405)664-6196

info@platinumhomesokc.com

www.platinumhomesokc.com

## **Aaron Tatum Homes**

Aaron Tatum (405)409-0027

[aaron@tatumhomes.com](mailto:aaron@tatumhomes.com)

[www.tatumhomes.com](http://www.tatumhomes.com)

## **Manchester Elite Homes**

Larry Mattocks (405)409-8000

larry@manchesterokc.com

www.manchesterokc.com

FINAL PLAT  
OF  
**ANTONS LANDING**  
A PART OF THE SW/4 OF SECTION 7, T11N, R4W, I.M.  
OKLAHOMA CITY, OKLAHOMA COUNTY, OKLAHOMA

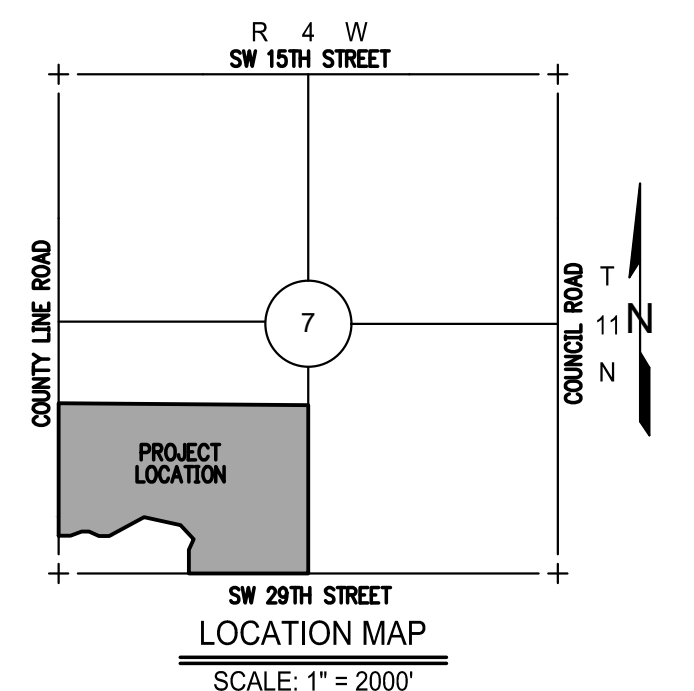
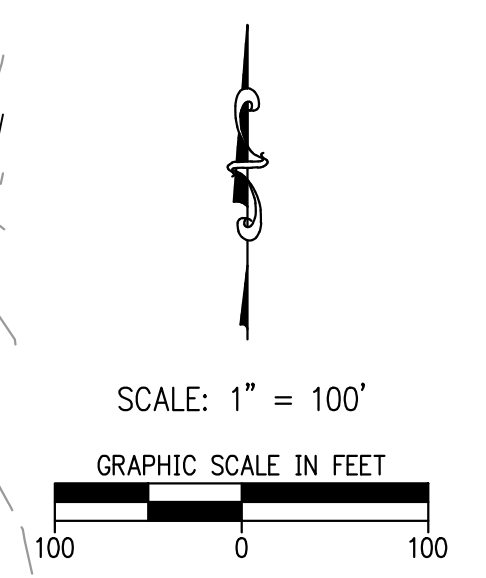
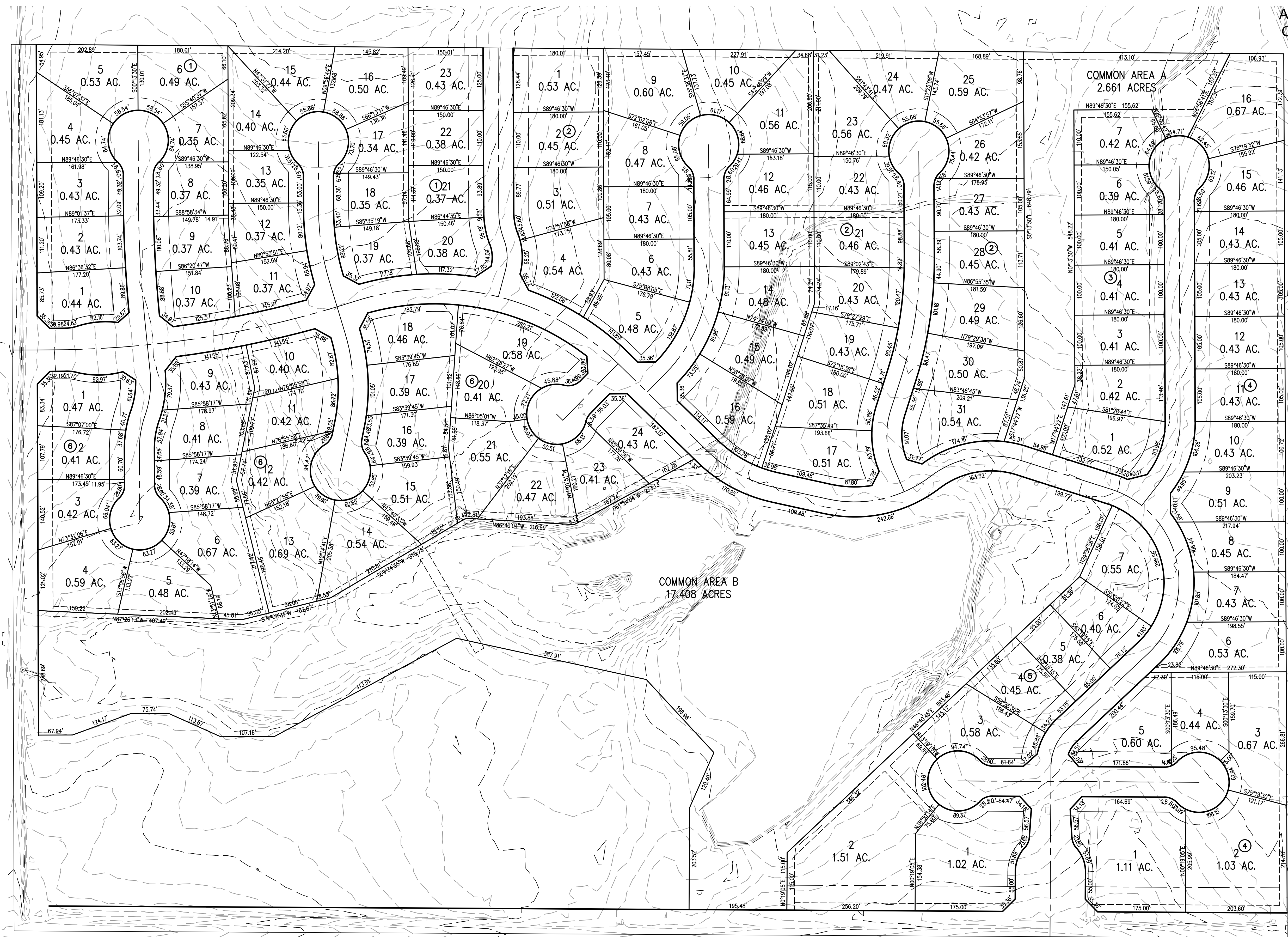

FINAL PLAT TO SERVE ANTONS LANDING	
<small>300 Pointe Parkway Blvd. Yukon, Oklahoma 73099</small>	
 <b>Crafton Tull</b> <small>architecture   engineering   surveying 405.787.6270   405.787.6276 f www.craftontull.com</small>	SHEET NO.: 2 OF 2 DATE: 02/27/18 PROJECT NO.: 16609700

CERTIFICATE OF AUTHORIZATION  
CA 978 (REPLACES EXPIRES 4/30/2018)



0' 100' 200' 400'