

EST. 1889

ANTON'S LANDING

Labor omnia vincit

To: Anton's Landing Visitor
From: Lawson Crout, Developer
RE: Anton's Landing

Thank you for your interest in the unique new Anton's Landing community in Oklahoma City. Join us as we transform the historic Swatek homestead and farm into a community of authentic urban farm homes. We have used Open Space design principles to create a safe, park like atmosphere for our residents. Efforts are being made to preserve the undisturbed landscape enjoyed by early Oklahomans.

This 102 acre gated community includes only 108 urban home sites served by full city utilities. Lot sizes range from 1/3 to over 1 acre each, and minimum home sizes range from 2200 to 4000 square feet depending on location in the community.

Enclosed please find a plat showing lot availability, a price sheet, a list of our Exclusive Builders with their contact information and a synopsis of the Covenants & Restrictions. The Covenants & Restrictions in their entirety can be found on our website.

Our builders are ready to prepare your perfect urban farm home in Anton's Landing. If you have any questions, or to reserve your lot, please call or email soon.

www.croutcompanies.com

P.O. Box 250 ~ 1452 N. Mustang Rd., Suite 108~ Mustang, OK 73064

For information call 405-376-3704 or email: lindsay.croutcompanies@yahoo.com

Doing Right By The Land In Mustang Since 1977

Anton's Landing

Lot Inventory - Phase I

<u>Lot</u>	<u>Block</u>	<u>Status</u>	<u>Min. Sq. Ft.</u>	<u>Notes</u>	<u>Acre</u>	<u>Pricing</u>
1	1	Available	2200		0.37	\$ 88,900
2	1	Available	2200		0.37	\$ 88,900
3	1	Available	2200		0.35	\$ 88,900
4	1	Sold	2200		0.40	Sold
5	1	Available	2200		0.44	\$ 89,900
6	1	Sold	2200		0.50	Sold
7	1	Available	2200		0.34	\$ 88,900
8	1	Available	2200		0.35	\$ 88,900
9	1	Available	2200		0.37	\$ 88,900
10	1	Available	2200		0.38	\$ 88,900
11	1	Available	2200		0.37	\$ 88,900
12	1	Available	2200		0.38	\$ 88,900
13	1	Available	2200		0.43	\$ 89,900
1	2	Sold	2200		0.53	Sold
2	2	Available	2200		0.45	\$ 88,900
3	2	Sold	2200		0.51	Sold
4	2	Sold	2200		0.54	Sold
5	2	Sold	2200		0.48	Sold
6	2	Available	2200		0.43	\$ 88,900
7	2	Sold	2200		0.43	Sold
8	2	Sold	2200		0.47	Sold
9	2	Sold	2200		0.60	Sold
10	2	Sold	2200		0.45	Sold
11	2	Sold	2200		0.56	Sold
12	2	Available	2200		0.46	\$ 88,900
13	2	Available	2200		0.45	\$ 88,900
14	2	Sold	2200		0.48	Sold

Anton's Landing **Builders List**

J. Hill Homes

Jeremy Hill (405)408-9602

jhillhomes@gmail.com

www.jhillhomes.com

Platinum Homes, LLC

Josh Julian (405)664-6196

info@platinumhomesokc.com

www.platinumhomesokc.com

Aaron Tatum Homes

Aaron Tatum (405)409-0027

aaron@tatumhomes.com

www.tatumhomes.com

Manchester Elite Homes

Larry Mattocks (405)409-8000

larry@manchesterokc.com

www.manchesterokc.com

FINAL PLAT
OF
ANTONS LANDING

A PART OF THE SW/4 OF SECTION 7, T11N, R4W, I.M.
OKLAHOMA CITY, OKLAHOMA COUNTY, OKLAHOMA

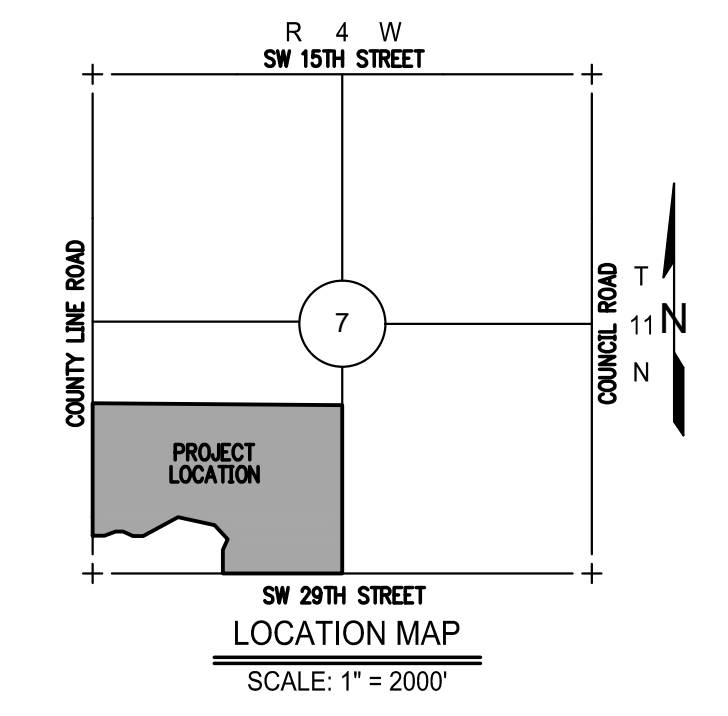
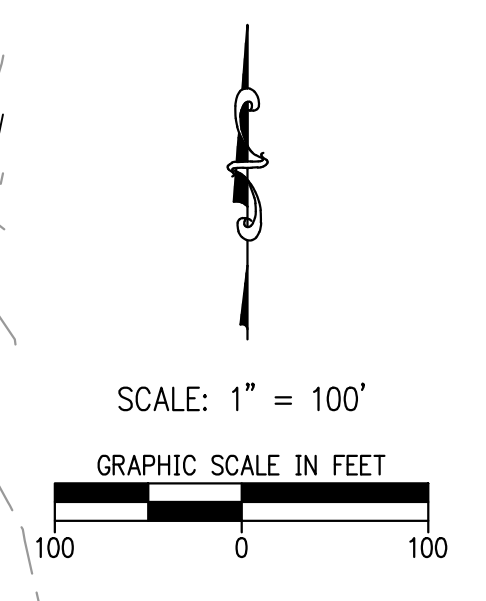
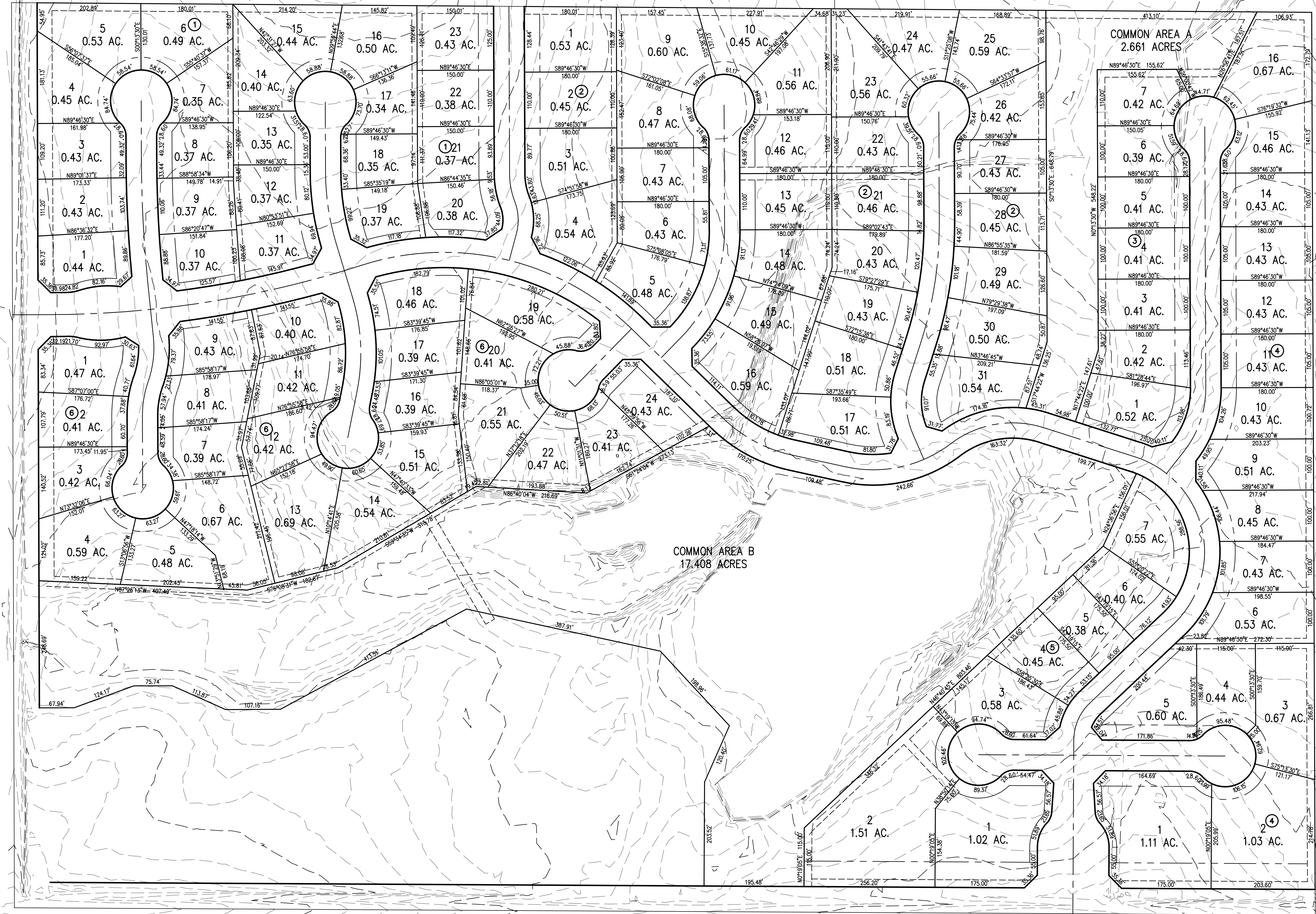

FINAL PLAT TO SERVE
ANTONS LANDING

300 Pointe Parkway Blvd.
Yukon, Oklahoma 73099

Crafton Tull
architecture | engineering | surveying
405.787.6270 | 405.787.6276 |
www.craftontull.com

SHEET NO.: 2 OF 2
DATE: 02/27/18
PROJECT NO.: 16609700

CERTIFICATE OF AUTHORIZATION:
CA 978 (PLAT) EXPIRES 4/30/2018



0' 100' 200' 400'